

Spacer Coupling

The Spacer Coupling is used to extend the distance of a shaft. Designed in conjunction with the Tyre Coupling specifications, it can be used in combination with other couplings in the Finer Power Transmission range.

As the Spacer Coupling is Taper Locked, a large range of shaft sizes can be easily accommodated.

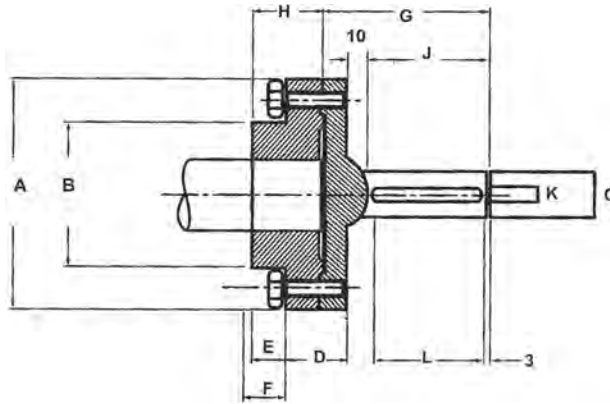

Spacer Coupling

Size	Bush	A	B	C	D	E	F	G	H	J	K	L	Kg
SM16-140	1615	127	80	32	33	20	25	131	41	109	10	65	4.0
SM25-140	2517	178	127	48	38	23	27	131	48	108	14	72	8.9
SM25-180	2517	178	127	48	38	23	27	171	48	148	14	78	9.1
SM30-180	3030	216	146	60	49	47	34	171	79	144	18	80	18.70

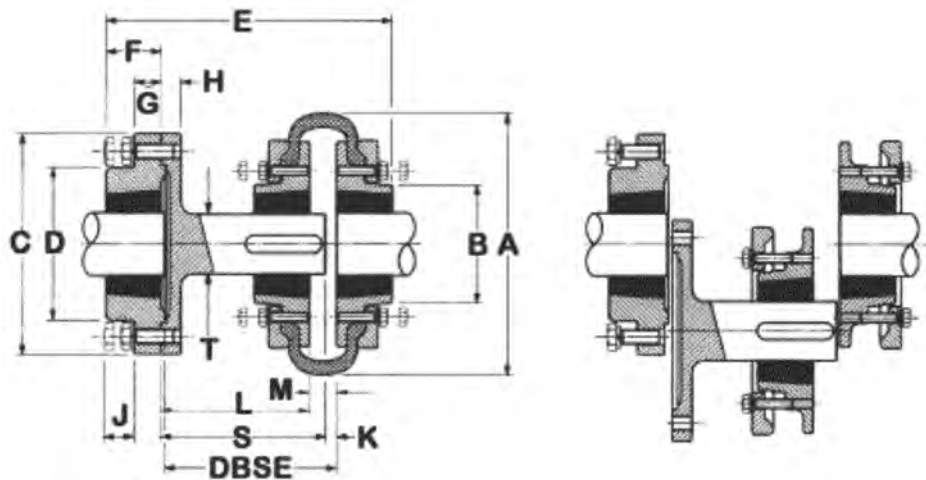

Spacer Coupling with Tyre Coupling

Size	Tyre Couple	Spacer Distance	Spacer Bush	Tyre Bush	A	B	C	D	E	F	G	H	J	K	L	M	S	T
SM16-140	T40	140	1615	1008	104	82	127	80	200	38	18	15	14	9	126	22	94	32
	T50			1210	133	79			213						125	25	134	
	T60			1610	165	70			214						118	27	134	
SM25-140	T80	140	2517	2517	211	95	178	123	233	45	22	16	14	9	116	25	134	48
	T90			2517	235	108			233						116	27	134	
SM25-180	T80	180	2517	2517	211	95	178	123	273	45	22	16	14	9	158	25	174	48
	T90			2517	235	108			273						156	27	174	
SM30-180	T100	180	3030	3020	254	120	216	146	310	76	29	20	17	9	156	25	174	60
	T110			3020	279	134			310						158	27	174	